

DSC4.4-PRO

Professional Quad-Channel Sound Controller

Release July 2018

Features

Powerful and Precision 32-Bit Floating-Point Process Arithmetic
 Audio-In/Out by On-Board 24-Bit Stereo ADC & DAC @ 48K Sample-Rate
 85dB Wide Range Audio-Input Level Meters with Peak & Hold Function
 4-Wire Serial-Data to 8-Bit SR Interface for Standard Character LCDs
 Clock-Sync & Power-Up Trigger Outputs for External Circuits Control
 During Operation 100% Click-Noise-Free Parameter-Adjustments
 20 User- & 20 Factory-Presets Storage by On-Board NV-Memory
 4 Independent LED-Outputs for Audio-Signal Clip, Limiter & Mute
 9 Different Applications Selectable by On- or Off-Board Jumpers
 48 Full Parametric EQs, Notch, Shelving, AllPass, VariQ Filters
 8 Independent Delays for Driver & Run Time Compensation
 Firmware Update Possibility via USB/ LAN by PC Software
 Windows PC Based Full Remote Control by USB or LAN
 4 Separated "Audio-Signal-Free" Volume-Control Inputs
 Various Link-Functions for Parameter Parallel-Settings
 RMS Limiter with variable Low Cut Filter per Channel
 Each Channel with Full variable Xover HPF & LPF
 Password Protection against Unauthorized Access
 Special Adaptions and Extensions on Request

Versatile Parameter Control Methods

Potentiometer for Volume Control by DCV
 Momentary Push Switches
 Rotary Quadrature Encoders
 10/100 Ethernet Interface (LAN, external)
 USB-Interface (HID)

Function & Parameter Indication Methods

Character LCD 2x16, 4x16
 Windows PC, LAN / USB

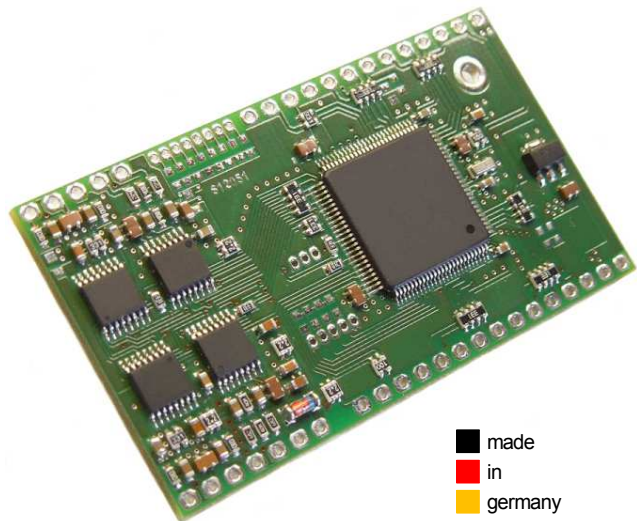

made in germany

Audio Signal 32-Bit DSP Gear

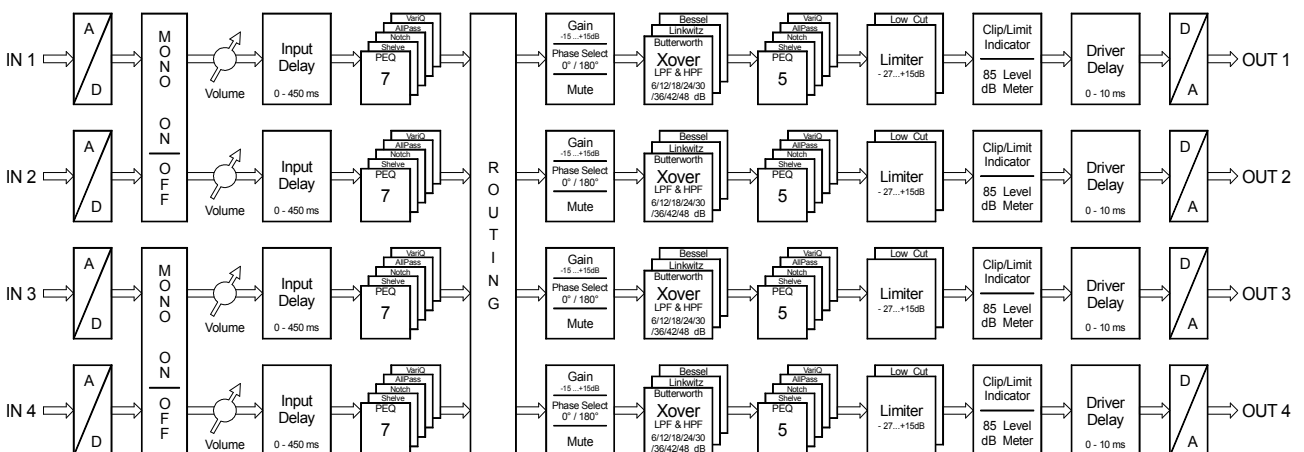

Applications

- Quad-Channel Power Amplifiers
- Dual-Channel 2-Way Active Speaker Cabinets
- Single-Channel 3/4-Way Active Speaker Cabinets
- Quad-Channel Full-Range Speaker Systems
- Stand Alone Sound Controller

Simplified Diagram

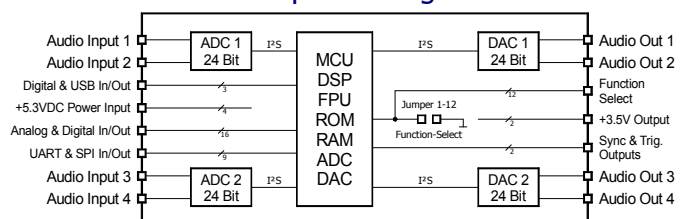

Technical Data

DSP Arithmetic	: 32-Bit Floating-Point
Audio AD/DA Conversion	: 24 / 24-Bit
S/N (A-Weighted)	: 110 dB @ 1KHz
Dynamic Range	: 110 dB
Frequency Response	: 10 Hz - 22 KHz / -3dB @ 48K fs
Max. Audio Input Level	: 15 dBu (12.3 Vpp)
Audio Input Impedance	: 10 Kohm
Input Stop-Band Attenuation	: 80 dB / 27KHz @ 48K fs
Max. Audio Output Level	: 3.3 dBu (3.2 Vpp), 15 dBu w. ext. buffer
Max. Audio Output Load	: 5.0 Kohm
Cross-Talk Attenuation 1/2, 3/4	: 85 dB @ 1KHz (0 dBu In/Out)
Cross-Talk Attenuation 1/3, 2/4	: 105 dB @ 1KHz (0 dBu In/Out)
Max. Audio Delay per Channel	: 460 ms @ 48K fs
Group Delay (Latency)	: 1.04 ms @ 48K fs
Power Supply Analog	: min. +5.2 V / max. +5.4V (OV protected)
Power Supply Digital	: min. +5.0 V / max. +9.0V
Power Consumption	: 150 mA (no external load)
Analog / Digital Control Inputs	: 16 (12-Bit ADC, 0 - 3.5V)
Analog Control Outputs	: 2 (12-Bit DAC, 0 - 3.5V)
Auxiliary DC-Outputs	: 2 (+3.5V / 50mA)
Quadrature Encoder Type	: 24 Pulses per Rotation
SPI - Interfaces	: 2 (MOSI, MISO, CLK)
USB - Interface	: 1 (HID, Full Speed)
USART - Interfaces	: 2 (TX / RX)
Sync - Clock Output	: 1 (3072 KHz @ 48K fs)
System - Ready Output	: 1 (active low after 1.5 sec delay)

Module Dimensions (mm)

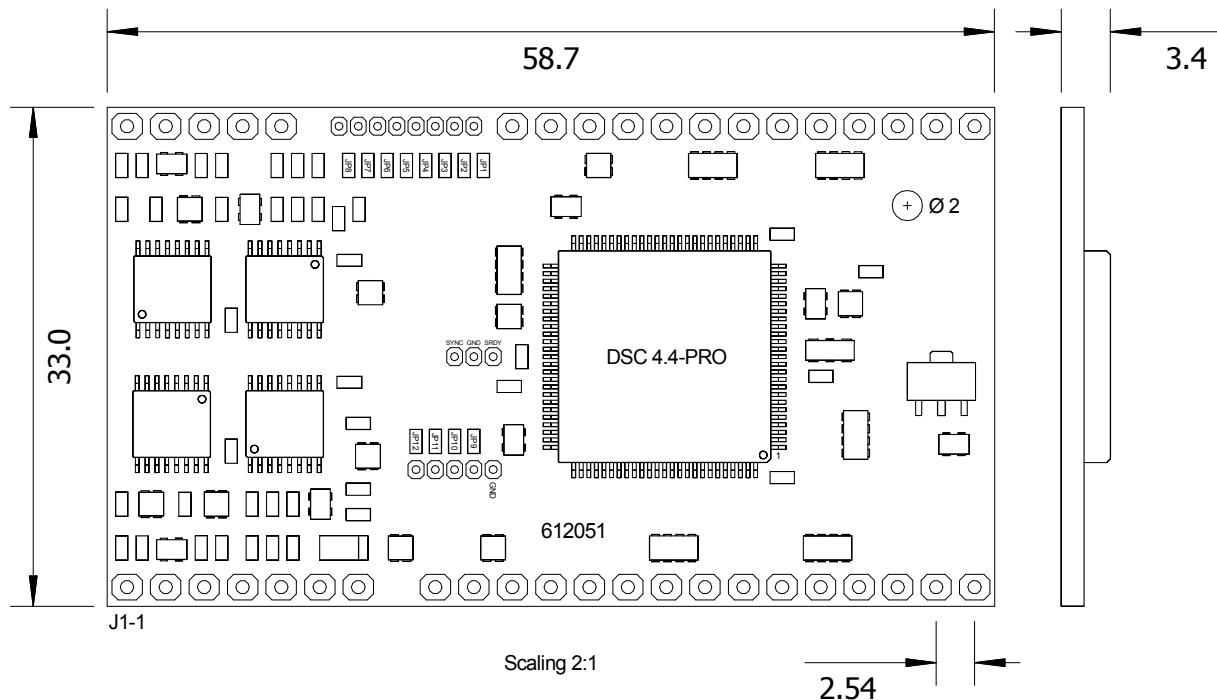

Contact Information

JAPAN: THK Co., Inc., 3-2-10 Tsukimiyama-cho, Suma-ku, Kobe 654-0063; Phone: ++81-78-732-7512, 7514; Fax: ++81-78-732-7513
 web: www.thk-japan.com; email: thk-kobe@jb3.so-net.ne.jp

GERMANY: MME, D-94060 Pocking, Sudetenstrasse 16; Phone: ++49-8531-41506; Mobile: ++49-175-5519115; email: baderoeder@freenet.de